

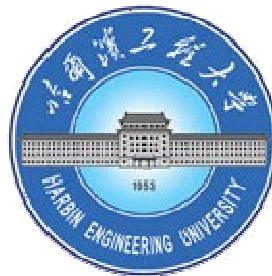

**Autonomous Underwater Vehicle from Harbin Engineering University**



**Autonomous Vehicle Development Team  
2014**



**Abstract** - The under water robot team of HEU(Harbin Engineering University) has been built for many years. In recent years we have attended many robot competitions, and gained many experiences. We constantly improve our robot and hope our robot to have perfect performance .So there is a big change of the software design. In this year we use the function block design pattern in order to reduce the block complexity and increase the expansibility. We want to do some idea exchange and communicate with others through this opportunity.

### I. THE NAVIGATION PART

The core of hydrophone signal processing system uses 32 bit fixed point DSP-TMS320F2811 of TI company .The system receives underwater acoustic data which measured by hydrophone through the serial bus, processes data, gets the source location information and issue the motion control commands to make the robot move to the target location. The hardware platform of signal processing system of hydrophone are shown as Fig.1.1.

Hydrophones placed in the 4 diagonal is mainly for positioning of underwater beacon through the correlation algorithm.



Fig. 1.1 Hydrophone signal processing module

### II. THE SOFTWARE PART

A good program needs not only beautiful structure and gorgeous interface, more to have better running efficiency. In this year, we use the function block design pattern. The whole design doesn't seem to be complex just like last year. The program design was written by one person before. Due to program is huge, it is difficult for a person on some details, such as image processing. Now to focusing on the future we use block design pattern. With the increase of software group members, each person can be responsible for a module, it's good for details.



Fig. 1.2 Hydrophone real

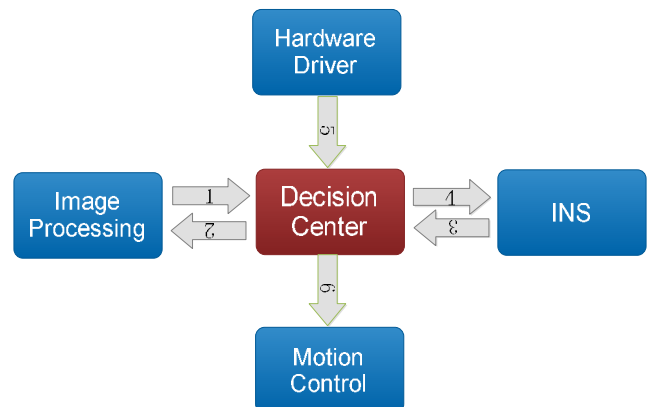

Fig. 2.1 The software frame picture

Now my application architecture is as shown Fig.2.1. It mainly divides into five parts and communicate with the Socket. Just like a person, decision-making centre is the brain, image processing is the eyes, motion control is hands, hardware driver is nose. inertial navigation (INS) is ears, and the Socket communication is just like nerve.

#### A. Decision Center

This part is mainly responsible for executive command. First of all, it will drives hardware to send information to module, and then through the image processing and inertial navigation (INS) to acquire sports information, and then send to the motion control module in order to complete the various tasks.



Fig. 2.2 Decision center interface picture

### B. Image Processing

This part is mainly responsible for the camera, clipping the target area, band pass and band-stop filter, the target characteristic information acquisition, as well as to identify the target, such as Path, Ball, etc., this part requires strong professional knowledge, the stand or fall of target identification directly relates to whether the task can become.



Fig. 2.3 Image processing frame picture

### C. Motion Control

This part is mainly responsible for the movement and manipulator control, for example, going forward, lateral translation, diving, turning and braking, etc. Image processing (or inertial navigation) through calculated can acquire the motor control signal, the decision centre sent it to motion control, after motion control, it will get the motor signal decoding value, and then send to the motor, the AUV motion.

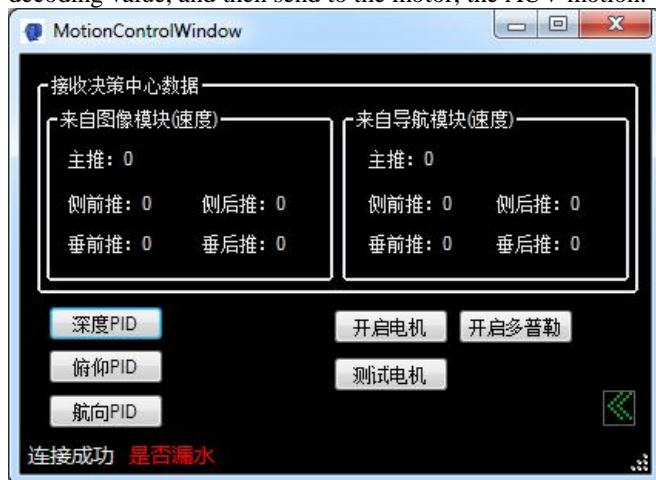

Fig. 2.4 Motion control frame picture

### D. Hardware Driver

This part mainly is to read all kinds of sensors, such as power supply information, inertial navigation information, hydrophone, Doppler and so on, then send the resolved value to decision center for the use of other modules.



Fig. 2.5 Hardware driver frame picture

## III. THE MECHANICAL PART

### A. Introduction

The structure of robot is just like a submarine, but not a round one. It is more like a fat fish. We made a new kind of propeller, which has 5 propellers, it is smaller and more powerful. Among the 5 thrusters, there are 2 fixed beside the vehicle to control the speed and heading of the vehicle, 2 fixed vertically to control up and down. There is also 1 horizontal thruster to control the robot to move forward and backward. This kind of arrangement can ensure our vehicle move freely and then accomplish missions easier. This time, we optimize the use of space, pressure hull and batteries are all positioned inside the non-pressure hull.

There is an embedded PC -GM45 and P7350 CPU in our vehicle to do image processing work and navigation. There is a STM32 control board in our vehicle to control the motors. All the datas of sensors are processed by STC12C5A60S2. A DSP board is used to process sonar information.

For improving the function of the FOG(Fiber optic gyro) and Doppler equipment we use to navigate, by using integrated navigation, the vehicle can move and make missions accurately.

Our team is make up of many students of different majors, they donated their own specialty to do robot competitions. They also learned so much and obtained many from this competition.

### B. General Design

The shape of the robot is roughly like a submarine, the cross section is not circular nor oval, it is a circle elongated from the diameter.

The whole scheme design of the robot consists three parts: propeller arrangement is located at head and tail and the pressure hull, battery, DVL and grabber is at the middle part of robot.

The SolidWorks 2012 and AutoCAD 2008 are used for the three-dimension design. The overall is made by carbon



fiber reinforced composite. It is lighter and stronger than the glass fiber reinforced plastics used last year.

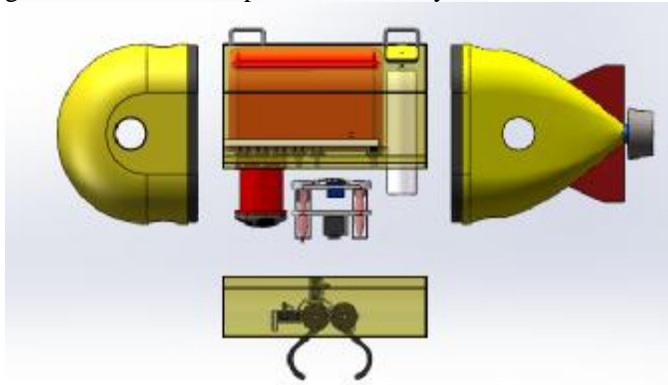

Fig. 3.1 The general design picture

### C. Propeller

All the thrusters are made by ourselves. The shell is aluminum and o-ring sealed. We use the brushless DC motor and planetary gear box. All the 5 propellers are driven by STM32 motor control board.

New propulsion has a smaller volume, but the power density is greater.

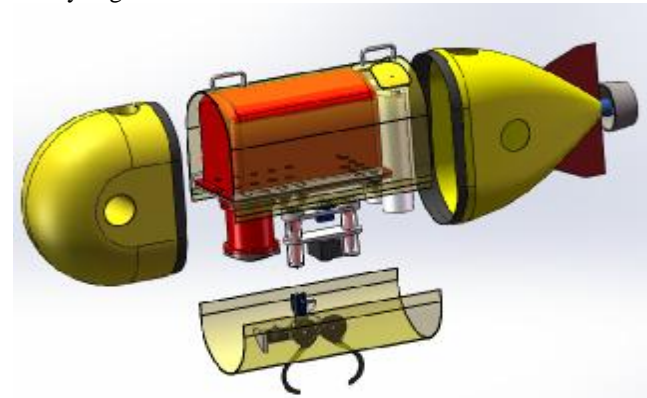

Fig. 3.2 The general design picture in another angle

### D. Marker Dropper

The marker dropper arrangement is located at the middle and lower of robot. Markers drop depends on gravity, and it can make the movement direction of the vertical downward automatically by the gravity and buoyancy adjustment. Before the launch, Markers stay in the robot by magnetic adsorption. The release mechanism was controlled by a servo motor. There is a camera in the middle of tubes which is used to storage markers.

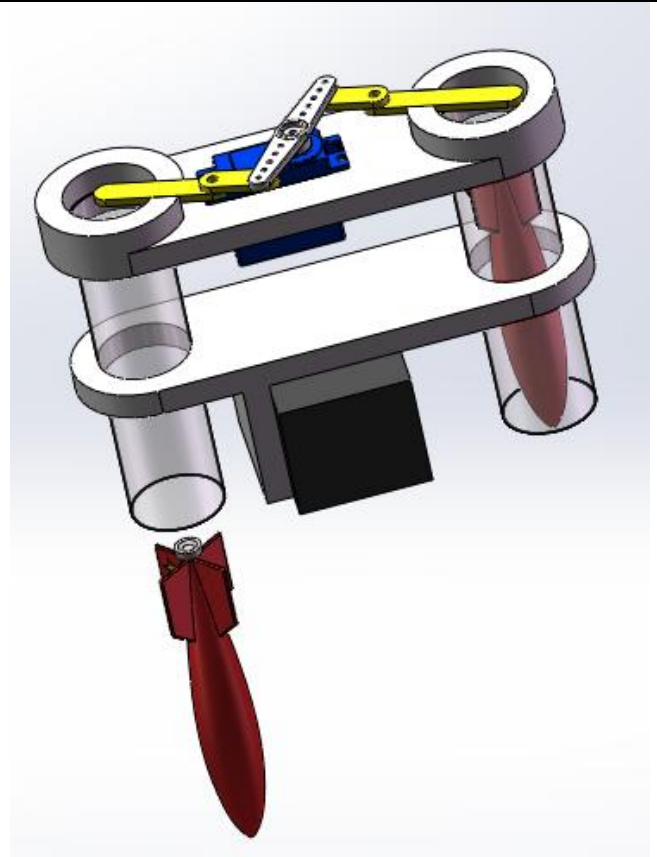

Fig. 3.3 Marker dropper picture

### E. Grabber

The grabber is located beside the marker dropper. There are two servo motors to control a pair of jaws for the stronger power. Two motors are synchronous, to drive the jaws to be open or closed.

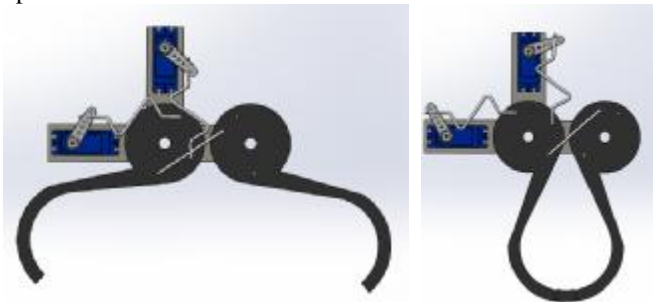

Fig. 3.4 Grabber picture

## IV. THE ELECTRICAL PART

The industrial computer is placed upon the FOG(Fiber optic gyro). The industrial cameras are connected on the GM45 board. The Doppler equipment is connected to the PC by UART port.

There are parts of the electrical subsystem. They are STM32 MPU, DSP board, power management, sensors board and FOG(Fiber optic gyro). All the modules are connect with each other by serial port. This structure is a parallel model, this



model makes it easier to install and uninstall the new attachment equipments.

The embedded PC model is GM45 with P7350 CPU. That's a industrial PC running under Windows XP OS. GM45 is the 3.5 inch mini board, Intel 945GM(E) and ICH7-M chipset, integrated GM45 graphics, DDR3 memory, Realtek AC97 Audio, Serial ATA and one Intel 82573L Gigabit LAN. The power input is 12V DC. It is equipped with a P7350 processor running at 2.0GHz and 2 GB of RAM and for vision, mission, and control processing. The PC communicates with the sensors, motor driver, servo driver, STM32 board and FOG(Fiber optic gyro) and Doppler equipment. Though UART and USB-UART converter. An intel 32GB SSD is used for onbo data storage. It is fully equipped with 4 USB2.0, 4 UART ports. There are 2 cameras connected with the computer by USB. Ethernet LAN is connected to the aluminum board, there is a special debug connector and cable for robot debugging so that we can login the computer remotely. The most convenient thing is that we can use this PC to debug STM32 and DSP board, because all the debug cables are connected to this PC and we don't have to open the hull to debug them.

#### V. STM32 BOARD

This board's CPU is a kind of ARM Cortex M3 chip, STM32F103VET6, it can run at 72MHZ. It can boost up within 10s. It is Performance line, ARM-based 32-bit MCU with Flash, USB, CAN, seven 16-bit timers, two ADCs and nine communication interfaces. This board has 3 UART, it is used to control the motors.

#### VI. DSP BORAD

The DSP board is shown in Fig.10. There's a TMS320F2810 on this board, it's in charge of the acoustic signal processing and depth date collection.

#### VII. CAMERA

There are two industrial cameras on our submarine, They communicate over a standard USB2.0 bus via a USB hub. And images are captured through Emgu CV. The Emgu CV is a cross platform, a ".NET" wrapper to the Intel OpenCV image processing library. The head camera is used to detect targets via colour filter and image processing algorithms. The down-camera is used to follow the path and choose bins.

#### VIII. POWER SUPPLY

There are 2 channels of power input from two independent batteries. Input voltage is between 12.8V and 14.2V. The maximum current can reach 10A. The battery pack is stored on the button floor of the main frame. These batteries are Ni-MH batteries with 4950mAh, it allows the vehicle to continue with its mission for at least 40 minutes at full power, longer than that during normal mission conditions. One group of cells is for control system and another group is for thrusters and mission execution unit. The battery pack is stored on the button floor of the main frame.

This unit has a power converter, it is designed for power control, it can convert the power to 3 standard voltage .They are 5V, 8V, 12V and directly output to embedded PC. 5V is for the miniARM2440 and DSP board and the controller on the motor driver board. The current and volt sensor will supervise the power situation.

#### IX. DEPTH SENSOR

The depth sensor is able to measure 0 to 2 bar and shown in Fig.12. An output of the depth sensor is analog current between 0~40mA potential to real depth and transmitted to the DSP board.